

GC02-20H
● FEATURES

- * Halogen-free type
- * Compliance to RoHS product
- * GPRC (Glass passivated rectifier chip) inside
- * Glass passivated cavity-free junction
- * Lead less chip form, no lead damage
- * Low profile package
- * For surface mounted applications
- * Plastic package has Underwriters Laboratory Flammability Classification 94V-0

● APPLICATION

- * General purpose rectification
- * Surge absorption

● MECHANICAL DATA

Case : Packed with FRP substrate and epoxy underfilled

Terminals : Pure Tin plated (Lead-Free), solderable per MIL-STD-750, Method 2026.

Polarity : Cathode Band, Laser marking

● PACKING

- * 3,000 pieces per 7" (178mm ± 2mm) reel
- * 4 reels per box
- * 6 boxes per carton

● OUTLINE DIMENSIONS
Case : 2010

Unit : mm

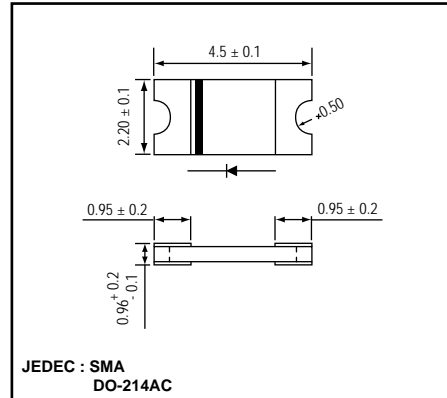

Absolute Maximum Ratings (Ta = 25 °C)

ITEM	Symbol	Rating	Unit
Repetitive peak reverse voltage	VRRM	2000	V
Average forward current	IF(AV)	1.0	A
Peak forward surge current (8.3ms single half sine-wave)	IFSM	30	
Operating junction temperature Range	Tj	-65 to +175	°C
Storage temperature Range	TSTG	-65 to +175	

Electrical characteristics (Ta = 25 °C)

ITEM	Symbol	Conditions	Value	Unit	
Maximum instantaneous forward voltage	VF	IF = 1.0A	2	V	
Maximum DC reverse current at rated DC blocking voltage	IRRM	VR = Max. VRRM	Ta = 25 °C	5	uA
			Ta = 125 °C	50	
Typical junction capacitance	Cj	VR = 4V, f = 1.0 MHz	8	pF	
Thermal resistance	Rth(JA)	Junction to ambient (NOTE)	65	°C/W	
	Rth(JL)	Junction to lead (NOTE)	15		

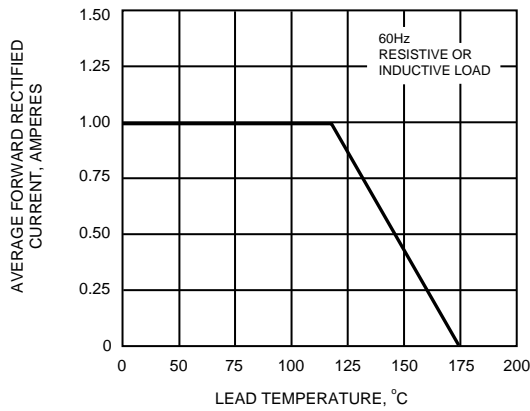
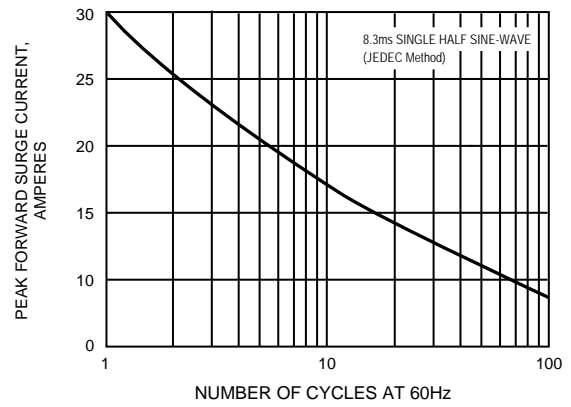
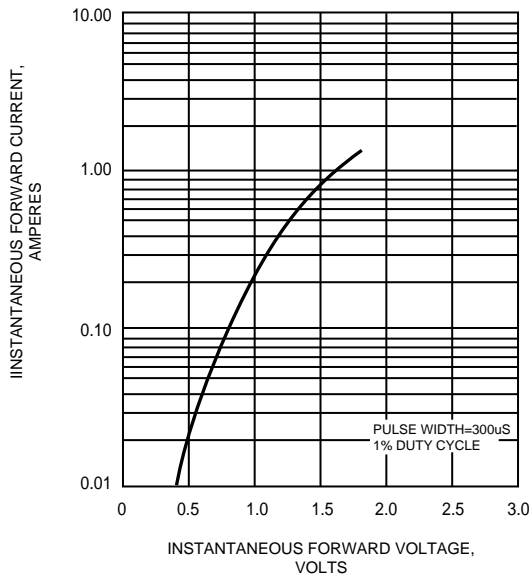
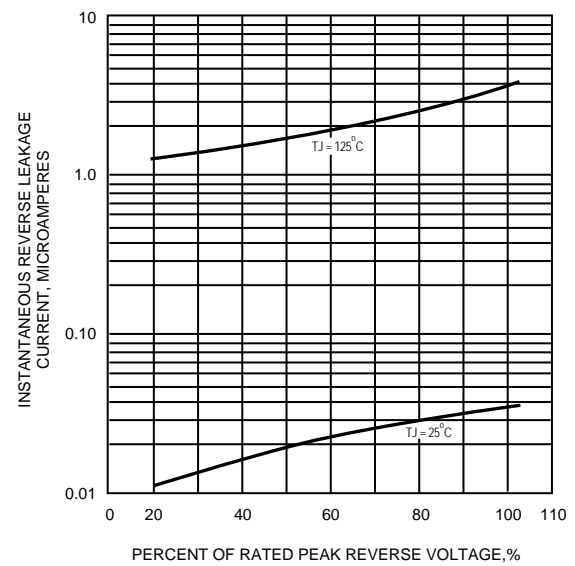
NOTE : Thermal resistance from junction to ambient and from junction to lead P.C.B. mounted on 0.2 x 0.2" (5.0 x 5.0mm) copper pad areas.

FIG.1 - FORWARD CURRENT DERATING CURVE

FIG.2 - MAXIMUM NON-REPETITIVE PEAK FORWARD SURGE CURRENT

FIG.3 - TYPICAL INSTANTANEOUS FORWARD CHARACTERISTICS

FIG.4 - TYPICAL REVERSE CHARACTERISTICS

FIG.5 - TYPICAL JUNCTION CAPACITANCE
